

Dimension:
Unit=mm

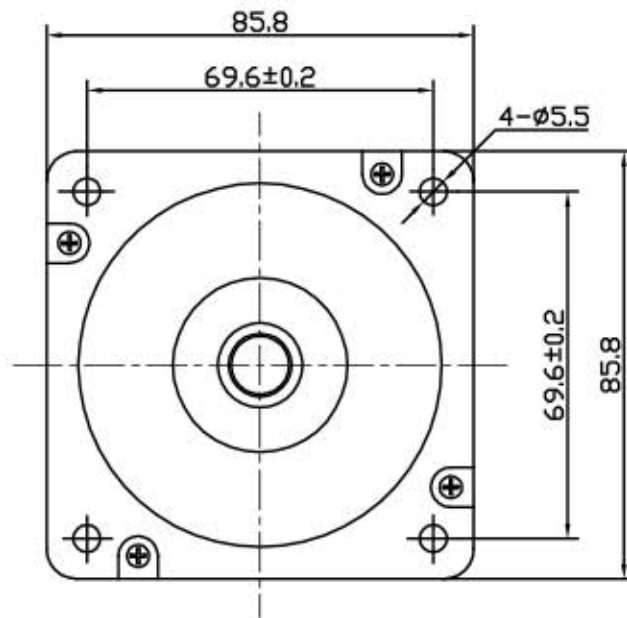
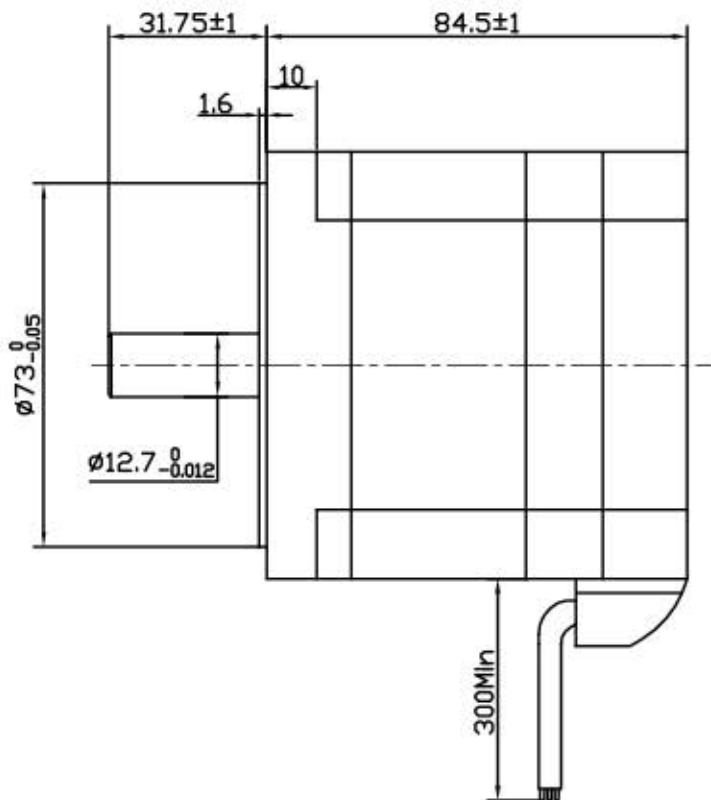

ROTATION: CW SEE FROM LEAD END

MANUFACTURER MODEL	JK86BLS71-X001
NUMBER OF POLES	8
PHASE TO PHASERESISTANCE	0.32 OHMS
NOMINAL VOLTAGE	48 VDC
NO LOAD SPEED	3700±10% RPM
NO LOAD CURRENT	1.5 Amps Max.
RATED TORQUE	0.7 N-m
RATED SPEED	3000±10% RPM
OUTPUT POWER	220 W
BACK EMF CONSTANT	13 V/kRPM
TORQUE CONSTANT	0.124 N-m/A
INSULATION CLASS	B

ELECTRICAL CONNECTION TABLE			
+5V	RED	红	UL1007 26 AWG
HALL U	YEL	黄	
HALL V	GRE	绿	
HALL W	BLU	蓝	
GND	GND	黑	UL1015 18 AWG
PHASE U	YEL	黄	
PHASE V	GRE	绿	
PHASE W	BLU	蓝	

Connection diagram:

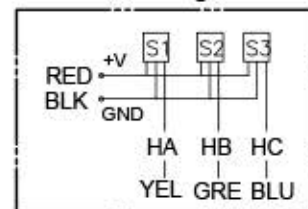

Hall sensor cable
Note: hall sensor power supply
voltage +5 to +20VDC

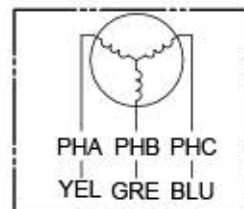

Wiring cable

				Title:			常州倍士福机电有限公司		
				Specification					
REV.	No.	SIG.	DATE	CLS.MAK	WEIGHT	SCALE	BF86BLS71-X001		
DESIGN		STD.							
CHECK									
PROC.		APPR.					PAGE: 1/1		
							www.besfoc.cn		