

Dimension:  
Unit=mm

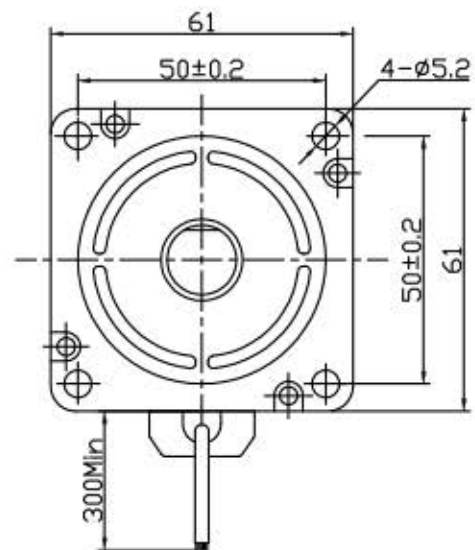

Connection diagram:

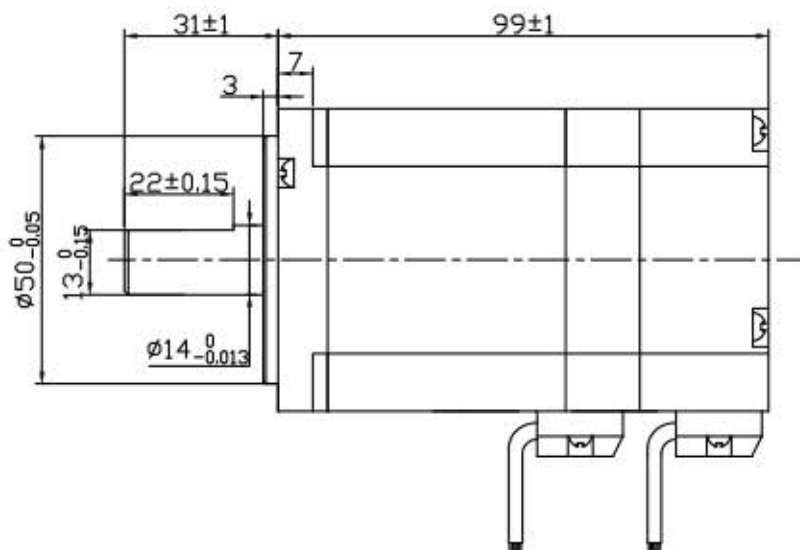
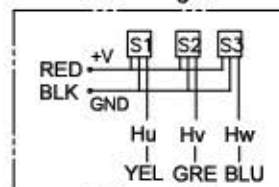

Hall sensor cable  
Note: hall sensor power supply  
voltage +5 to +20VDC

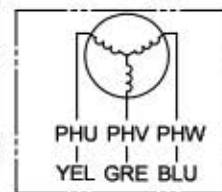

Wiring cable

ROTATION: CW SEE FROM LEAD END

MANUFACTUER MODEL	JK60BLS01
NUMBER OF POLES	8
PHASE TO PHASERESISTANCE	OHMS
NOMINAL VOLTAGE	48 VDC
NO LOAD SPEED	4000±10% RPM
NO LOAD CURRENT	Amps Max.
RATED TORQUE	0.65 N-m
RATED SPEED	3000±10% RPM
OUTPUT POWER	204 W
BACK EMF CONSTANT	V/kRPM
TORQUE CONSTANT	N-m/A
INSULATION CLASS	B

ELECTRICAL CONNECTION TABLE

+5V	RED	红	五芯屏蔽线
HALL U	YEL	黄	
HALL V	GRE	绿	
HALL W	BLU	蓝	三芯电缆线
GND	GND	黑	
PHASE U	YEL	黄	
PHASE V	GRE	绿	
PHASE W	BLU	蓝	

REV.	QTY.	No.	SIG.	DATE
DESIGN			STD.	
CHECK				
PROC.			APPR.	

Title:

Specification

CLS.MAK WEIGHT SCALE

PAGE: 1/1

常州倍士福机电有限公司

BF57HS56-2804-13

www.besfoc.cn