

HYBRID STEPPING MOTOR SPECIFICATION

DIMENSIONS unit=mm

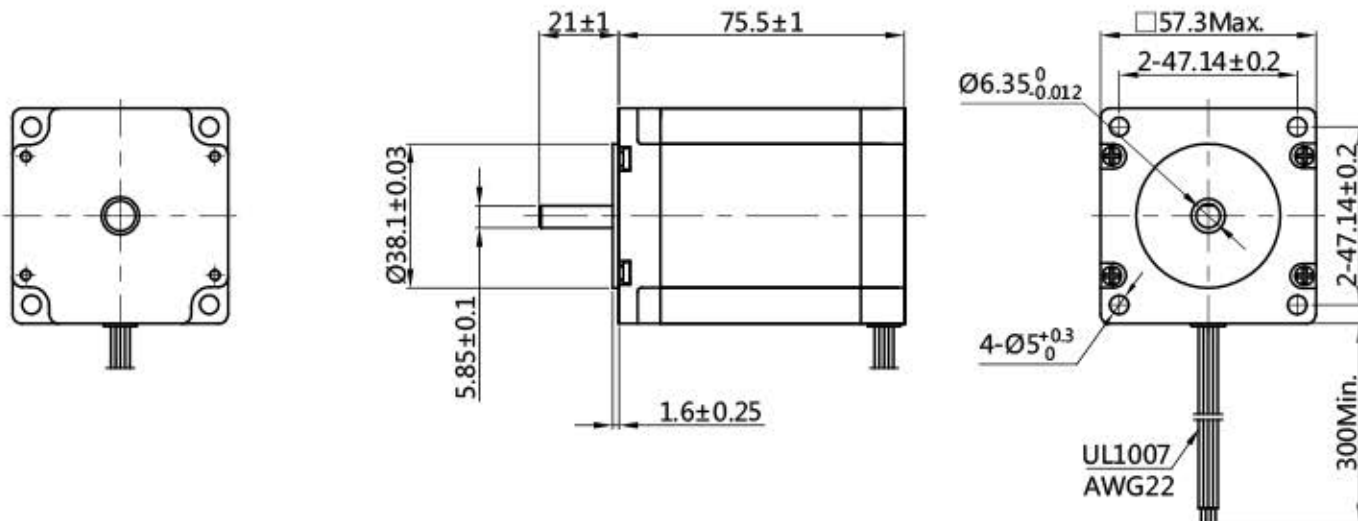

Wiring Diagram

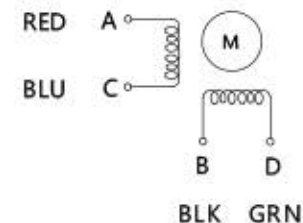

Exciting Sequence vs. Direction of Rotation

| STEP | A | B | C | D | |
|------|---|---|---|---|---------------|
| 1 | + | + | - | - | ↓ CCW ↑ CW |
| 2 | - | + | + | - | |
| 3 | - | - | + | + | |
| 4 | + | - | - | + | |

Clockwise view from mounting side

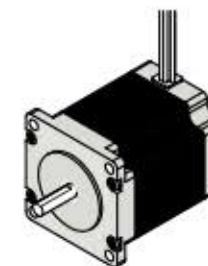

| | | | | | |
|------------------------|---------------------------------|----------------|--|------------|-----------------|
| 1. Number of Phase | 2 | | | | |
| 2. Step Angle | 18° deg. | | | | |
| 3. Rated Voltage | 3.08 V | | | | |
| 4. Rated Current/Phase | 2.8 A (Peak Value) | | | | |
| 5. Phase Resistance | 1.1 $\Omega \pm 10\%$ (20°C) | | | | |
| 6. Phase Inductance | 3.6 mH $\pm 20\%$ (1kHz 1V RMS) | | | | |
| 7. Holding Torque | 1.89 N.m | | | | |
| 8. Insulation Class | B (130°); 80K Max. | | | | |
| 9. Weight | 1.1 kg | | | | |
| Specifications | | Comment | | | |
| | | | | REV. | REVISION RECORD |
| | | | | DESIGN | 常州倍士福机电有限公司 |
| | | | | STANDARD | www.besfoc.cn |
| | | | | TECHNOLOGY | |
| | | | | CHECK | |
| | | | | APPROVE | |
| | | | | DATE | |

| | | | | | |
|----------|------------------|----------|-----|-------|--------|
| TITLE | STEPPING MOTOR | | | | |
| DWG.NO. | BF57HS76-2804-05 | | | | |
| MATERIAL | | ECN SIGN | ✳ | SIZE | A4 |
| REV. | A | SCALE | 1:2 | SHEET | 1 of 1 |